

Antimicrobial Surfaces: Physical and Chemical Functionalization

Iban Quintana | EIBAR, May 3th 2017



IK4  TEKNIKER

Research Alliance

Antimicrobial Surfaces

Overview

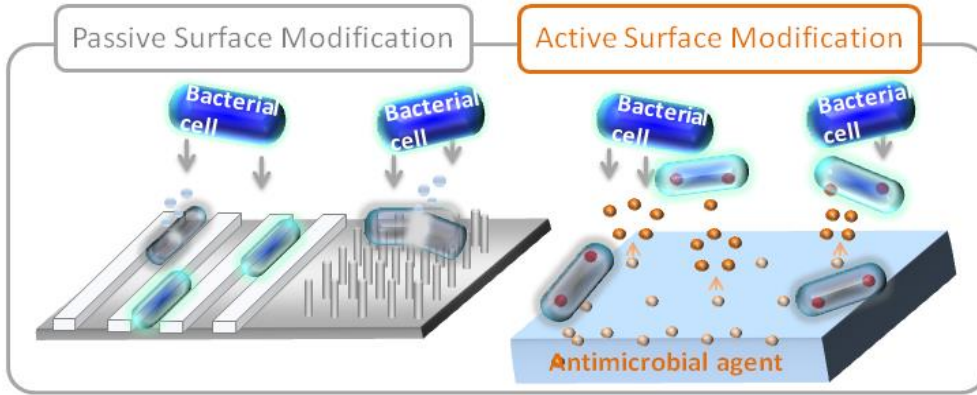

Passive Approach:

- Anti-biofouling
- Bactericidal

Active Approach:

- Coatings containing silver ions or NPs
- Antibiotics

Surface modification Strategy	Technical complexity	Versatility	Costs	Antibacterial Activity	Resistance induction	Toxicity/ Cytotoxicity
Passive methods	😊	😐	😐	😐	😊	😊
Active methods	😐	😐	😞	😊	😐	😞

Antimicrobial Surfaces: COMPLEXITY

Gram positive and Gram negative: p. aeruginosa (-), e-coli (-), s. aureus (+), s. epidermidis (+), etc.

Real life is more complex:

Infected wounds



Gram positive skin organisms and gram negative gut flora

Staphylococci, *MRSA*, *Pseudomonas*, *Acinetobacter*, Beta haemolytic *Streptococci*, *Enterococci*, Vancomycin Resistant *Enterococci*, *Corynebacteria*, *Bacteroides*, *Proteus*, *E.coli*, etc

Mature biofilms

Hip Joint infections



Predisposing factors

S. aureus, *Streptococci*, *e.coli*, *salmonella enterica*, *P. Aeruginosa*, *mycobacterias*, *campylobacter*, etc.

Biofilm formation: antibiotic resistance

Small colony variants: modification on bacterial cells development

Antimicrobial Surfaces: Passive Approach

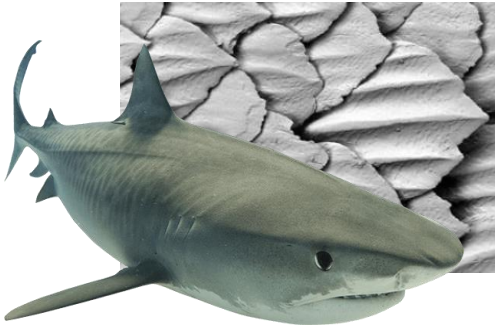
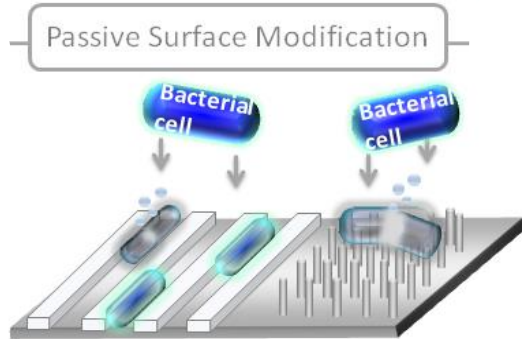

Technique	Advantages	Disadvantages	Antibacterial Capacity	Scalability
Chemical Etching (Black Silicon)	Biomimetic	<ul style="list-style-type: none"> Material limitation Time consuming (5 min., 100 mm²). 	P. aeruginosa: 4.3x10 ⁵ S. aureus: 4.5x10 ⁵ B. subtilis: 1.4x10 ⁵	☹️
Hydrothermal treatments (Titanium nanowires)	Size control Biomimetic	<ul style="list-style-type: none"> Material limitation Time consuming (1 mm/1 hour at 240°C). Expensive process 	S. aureus, E. faecali, K. pneumoniae: <10% P. aeruginosa, E. coli, B. subtilis: 40%-80%	☹️
Pulsed Polymerization + UV irradiation (photolithography)	Plasma + UV Substrate-independent High resolution	<ul style="list-style-type: none"> Geometrical restrictions Photocurable polymers required Time consuming 	E. coli: 13-33% bacterial adhesion reduction after 14 h	☹️
Direct laser interference patterning (DLIP)	High quality nano-features in a wide range of materials	<ul style="list-style-type: none"> Geometrical restrictions Depend on laser characteristics Small areas 	S. aureus: up to 60% reduction in adhesion	☹️
Ultrashort pulsed laser ablation	Hierarchical structures. Wide variety of materials. Large areas Robust equipment	<ul style="list-style-type: none"> Material limitation Time consuming Expensive 	On titanium. Decreased adhesion of P. aeruginosa ≈90% No effects on S. aureus.	😊
Roll2Roll nanostructuring	Large areas via nanostructuring of the roll – die.	<ul style="list-style-type: none"> Uses only flexible materials (films) 	E. coli: 32 % reduction in bacterial adhesion, considering PS, PE and PC	😊

<https://softmat.net/2012/05/anti-microbial-materials/>

Antimicrobial Surfaces: Passive Approach

Ps pulsed laser ablation: Direct microstructuring

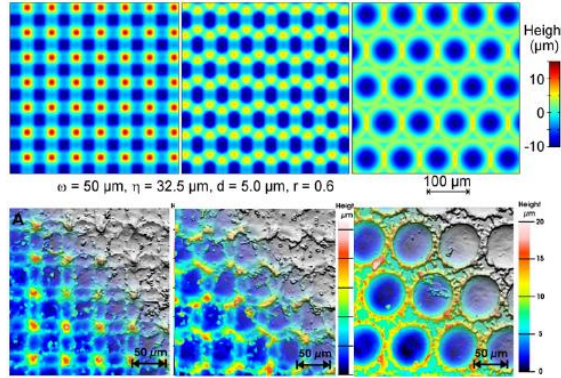

Black Silicon + Hot embossing

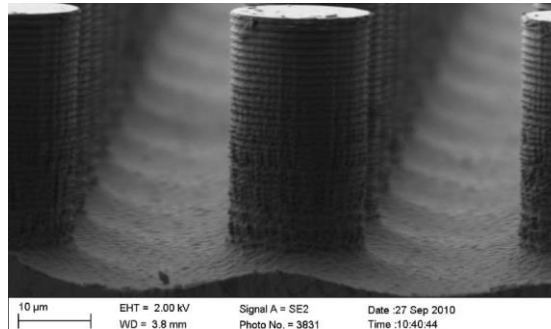

Technologies

- Wide variety of materials: Metals, ceramics, polymers, glass
- Adapted to 3D-Surfaces
- Reliable process.
- Replication of Nanostructures on thermoplastics and resins
- Submicro- and nanoscale
- Limited to flat samples

Antimicrobial Surfaces: Passive Approach

Results

Ps pulsed laser ablation: Direct microstructuring

Material: Titanium (ELI 23) (Ti6Al4V)

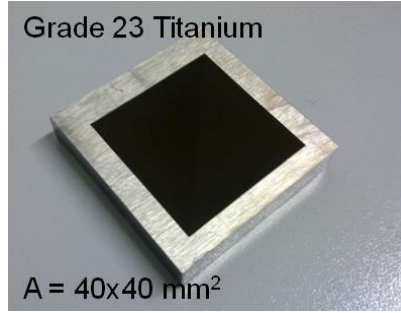

Three-fold scale topography:

- 1) *Major pattern*: micro-pyramids
- 2) *Minor pattern*: micro-spheres
- 3) *Ripples*: nanofeatures

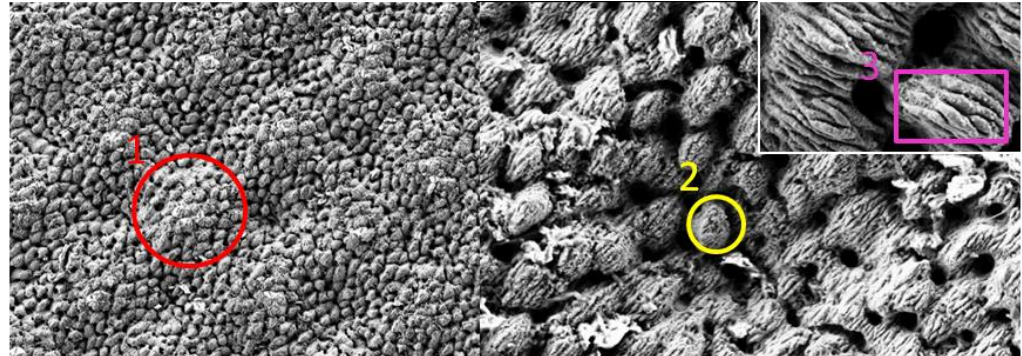

Antimicrobial Surfaces: Passive Approach

Results

Ps pulsed laser ablation: Direct microstructuring

Material: Titanium (ELI 23) (Ti6Al4V)

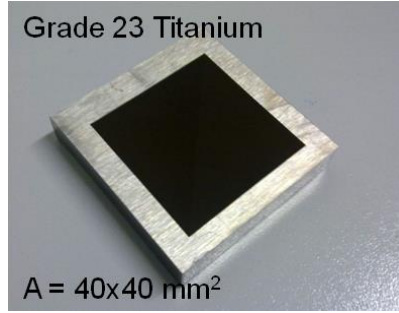

Two-fold scale topography:

- 1) ~~Major pattern~~: micro-pyramids
- 2) *Minor pattern*: micro-spheres
- 3) *Ripples*: nanofeatures

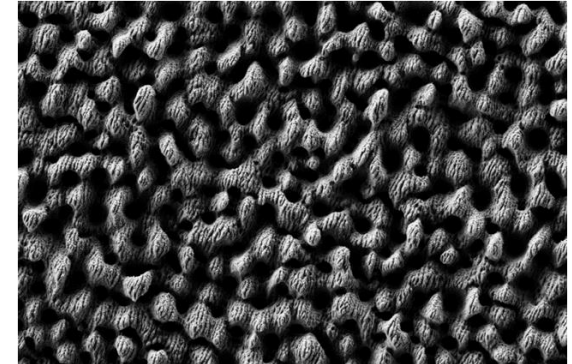
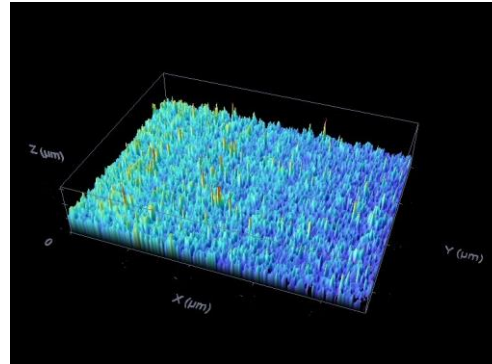

Antimicrobial Surfaces: Passive Approach

Ps pulsed laser ablation: Direct microstructuring

Antibacterial activity:

ISO 22196 or JIS Z 2801:2010

Percentage of the reduction in bacterial proliferation:

$$R (\%) = \frac{\text{Control} \left(\frac{\text{Bacterias}}{\text{cm}^2} \right) - \text{Texturizado} \left(\frac{\text{Bacterias}}{\text{cm}^2} \right)}{\text{Control} \left(\frac{\text{Bacterias}}{\text{cm}^2} \right)} \cdot 100$$

Three-fold topography

S. Aureus: **R = 98%**

S. Epidermidis: **R = 77%**



R > than results published at literature about antibacterial activity of nano/micropatterns (R = 50-90%).

Two-fold topography

S. Aureus: R = 0%

S. Epidermidis: R = 0%

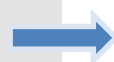

Not antibacterial activity was detected for both bacteria considered.

Results

Bacterial assays

Wettability

Non-patterned Ti



Contact angle = 90°

Patterned Ti (3fold)

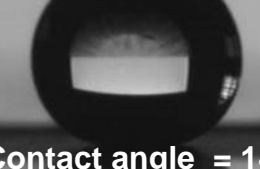

Contact angle = 148°

Patterned Ti (2fold)



Contact angle = 148°

Antimicrobial Surfaces: Passive Approach

Ps pulsed laser ablation: Direct microstructuring

Other Materials

Results

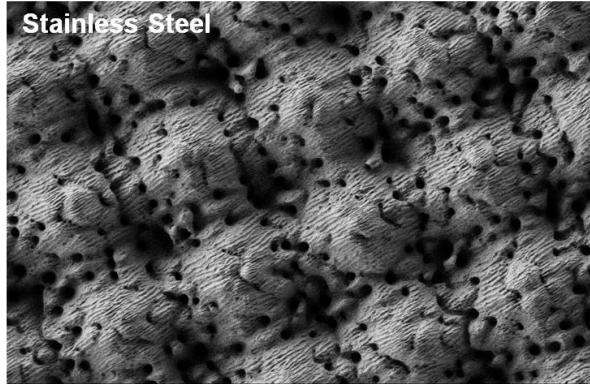

Hot Embossing

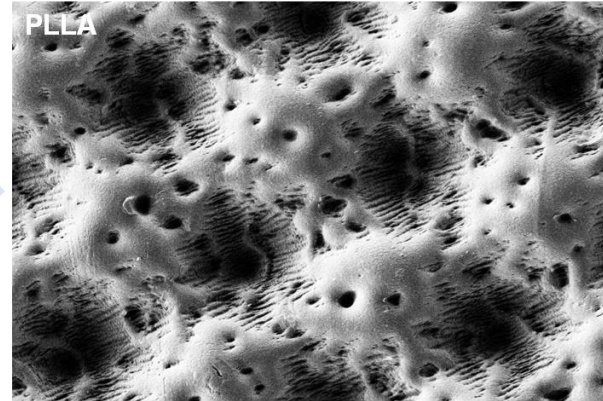

Effective
Replication

Bacterial assays in progress

Antimicrobial Surfaces: Passive Approach

Results

Black Silicon: Silicon Etching by RIE

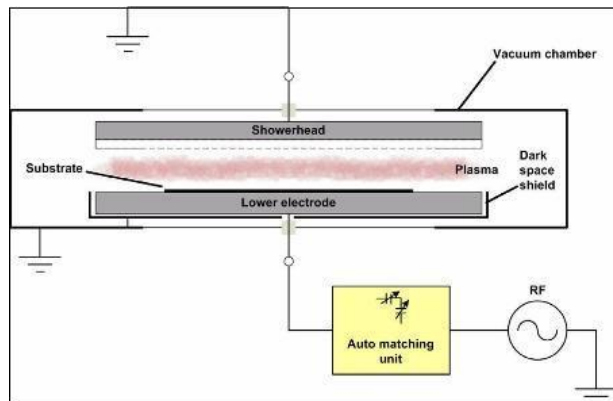

Process Parameters to control:

- SF₆/C₄F₈ ratio
- RF power (W)
- Chamber Pressure (mTorr)
- Etching time (s)



Height \approx 0.6 μ m
Density \approx 4.5x10⁶ pk/mm²
 ϕ = 0.3 μ m

Height \approx 2.2 μ m
Density \approx 1.5x10⁶ pk/mm²
 ϕ = 0.3 μ m

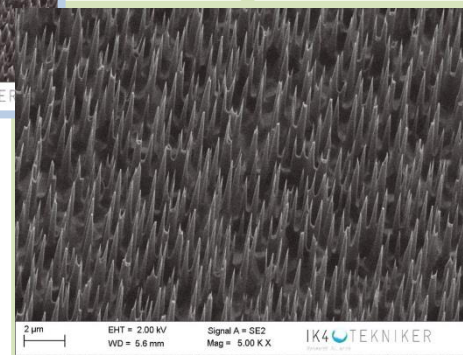

Height \approx 2.7 μ m
Density \approx 6.5x10⁵ pk/mm²
 ϕ = 0.2 μ m

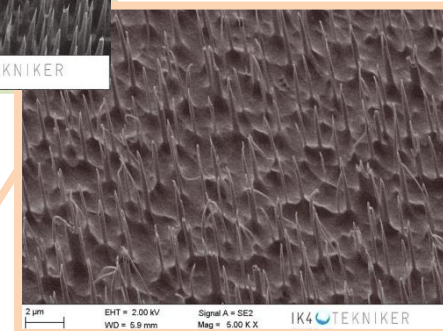

Antimicrobial Surfaces: Passive Approach

Results

Black Silicon: Silicon Etching by RIE + HOT EMBOSSING

Antibacterial activity:

Height $\approx 2.2 \mu\text{m}$
Density $\approx 1.5 \times 10^6 \text{ pk/mm}^2$
 $\phi = 0.3 \mu\text{m}$

Nanostructuring approach

S. Epidermidis: R(%) = 99.99% (R=4.76)

P. Aeruginosa: R(%) = 99.99% (R=5.75)



Replication
in polymers?

HOT EMBOSSING (PC)

Nanostructuring approach

S. Epidermidis: R(%) = 3.1% (R=0.02)

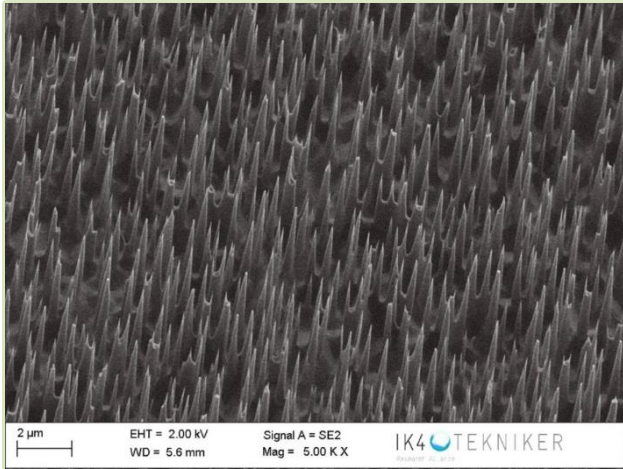

Bacterial colonization on PC
is one order of magnitude
lower than in Si



Antimicrobial Surfaces: “Active” Approach

Results

Active Surface Modification

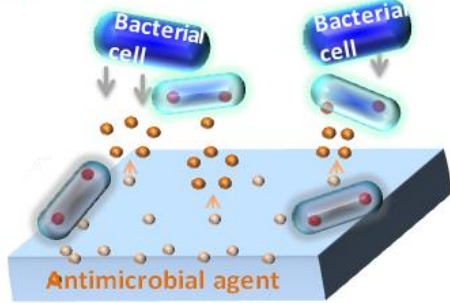

PVD coating: TaN + Metallic Dopant (MD)

- Excellent Tribological properties
- Biocompatible
- Radiopacity

TaN

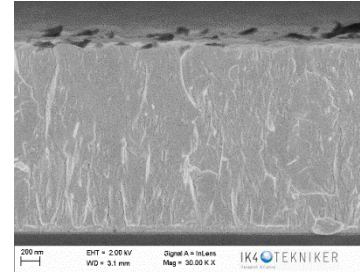

TaN+MD_1

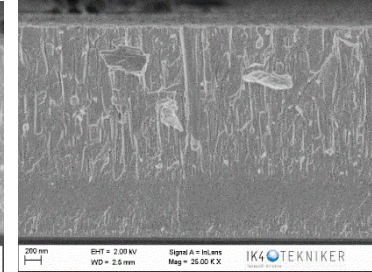

MD content < 50%

Non Cytotoxic

PVD coating approach

E. Coli (TaN+MD_1): R(%) = 99.6% (R=2.4)

E. Coli (TaN+MD_2): R(%) = 99.9% (R=4.8)

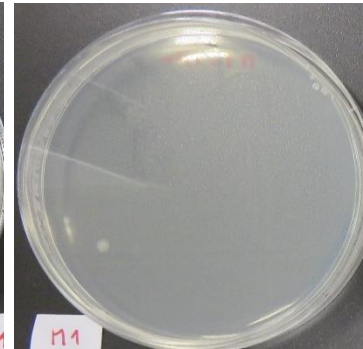
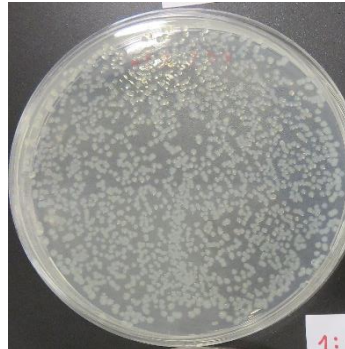

TaN+MD_1

TaN+MD_2

Antimicrobial Surfaces: “Active” Approach

Plasma Electrolytic Oxidation (PEO)

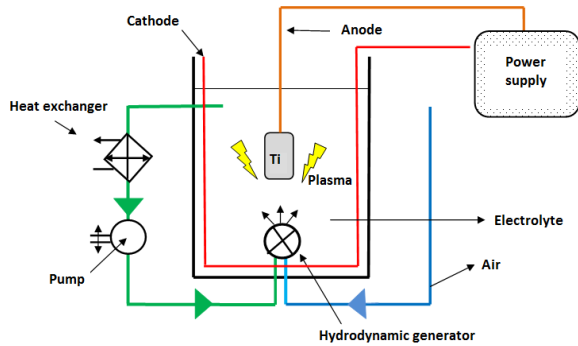

TiO₂, Titanium Oxide

- ✓ Hard coatings
- ✓ Prevent wear
- ✓ Excellent dielectric insulations
 - ✓ Prevent galvanic corrosion
 - ✓ Superior adhesion strength

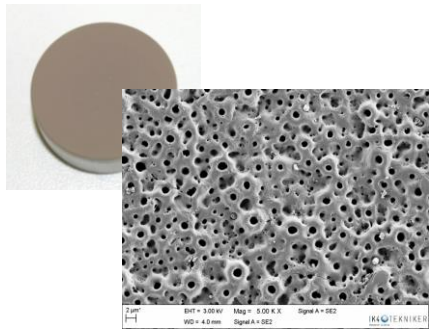
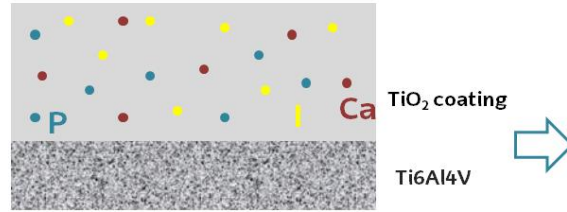

Iodine as biocide agent

Results

Antimicrobial Surfaces: “Active” Approach

Results

Plasma Electrolytic Oxidation (PEO)

Antibacterial activity: $TiO_2 + I$

- *S. aureus*
- *S. epidermidis*

Collection strains

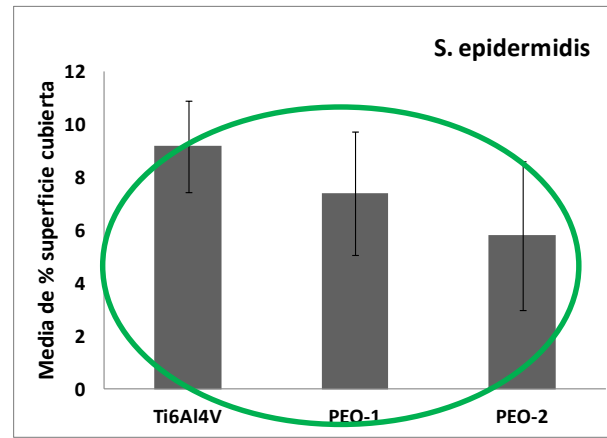
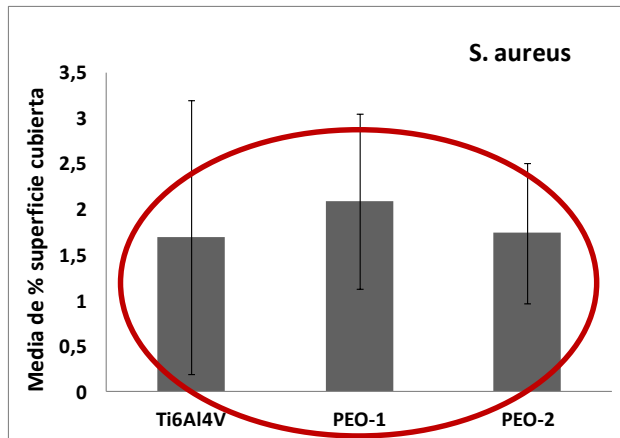
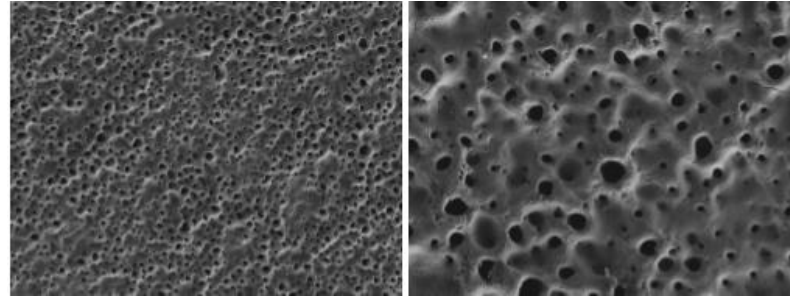

Antimicrobial Surfaces: “Pasive” and “Active” Approaches:

Results

UPSCALING CAPABILITIES AT IK4 - TEKNIKER

Laser microstructuring-cutting
of complex surfaces

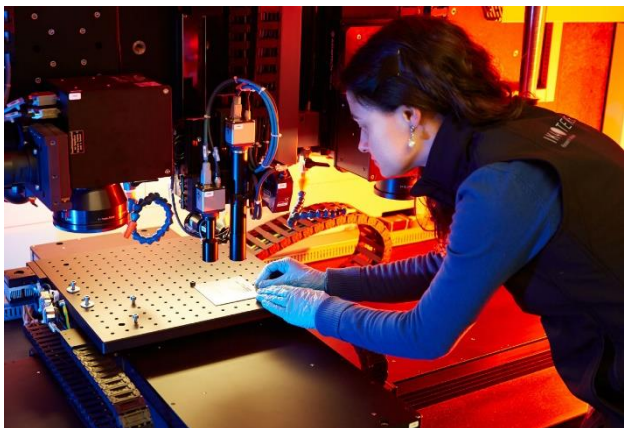

R2R NIL



UV-NIL and Thermal NIL

R2R PVD Process

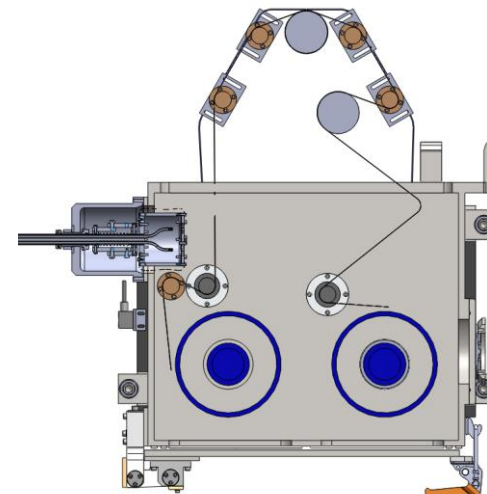

Web width: 100 mm

Speed: 10 m/min

Antimicrobial Surfaces

Conclusions

Antibacterial capacity of nano- and microstructuring surfaces depends on the substrate and bacterial type considered: There is no universal solution

Pattern customization has to be determined by considering both substrate and bacteria involved

Laser structuring of Ti substrate leads to good antibacterial capacity for *s. aureus* and *s. epidermidis* bacteria

Nanopatterning following the black silicon approach leads to excellent antimicrobial capacity for *s. epidermidis* and *p. aeruginosa*, only in silicon

TaN + Metallic Dopant coatings and PEO Surface solutions offer excellent results on tribological properties and antibacterial capacity (*e. coli*, *s. epidermidis*) of Ti substrates

All these technologies are applied on complex shape products and large area substrates via up-scaling strategies adopted by IK4-TEKNIKER

PARKE TEKNOLOGIKOA
C/ Iñaki Goenaga, 5
20600 EIBAR GIPUZKOA
SPAIN
www.tekniker.es



IK4  TEKNIKER

Research Alliance